

LOC		DIST		P		F		ZONE		LTR		REVISIONS		DATE	APPD	
AA	23												E	REV; EC0210-0797-94	1-24-95	TCS

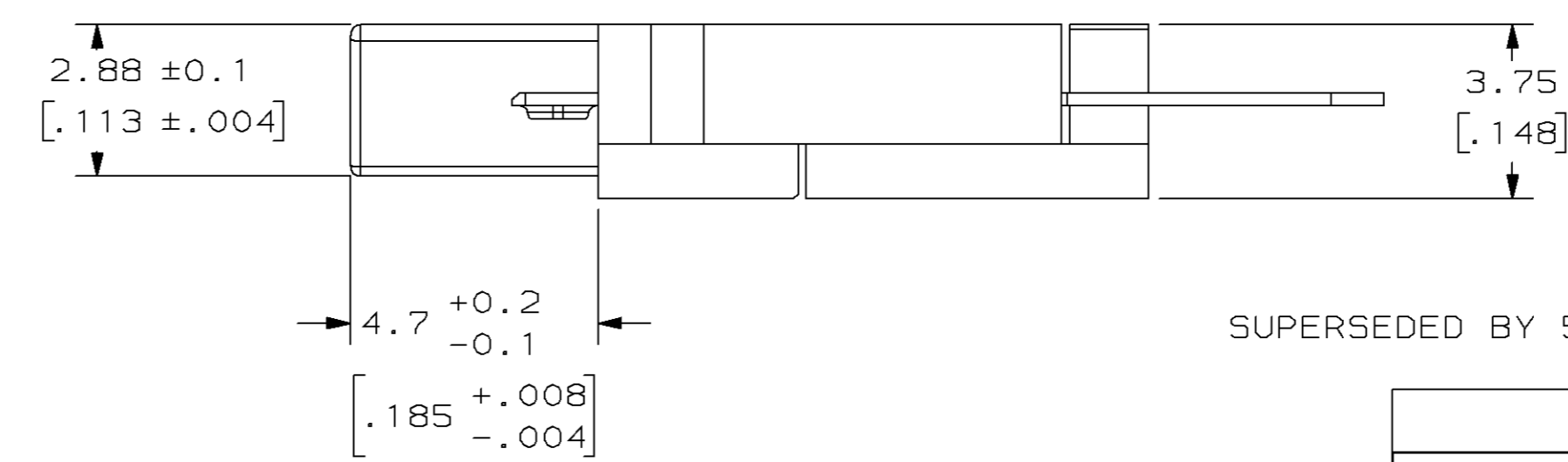
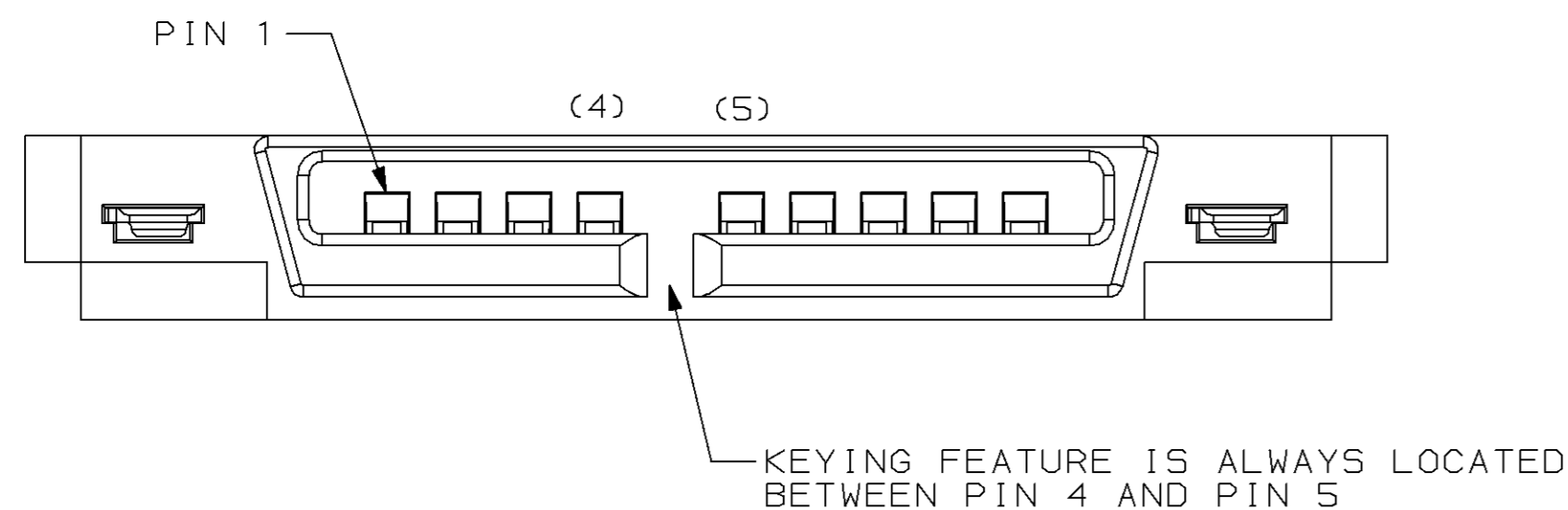
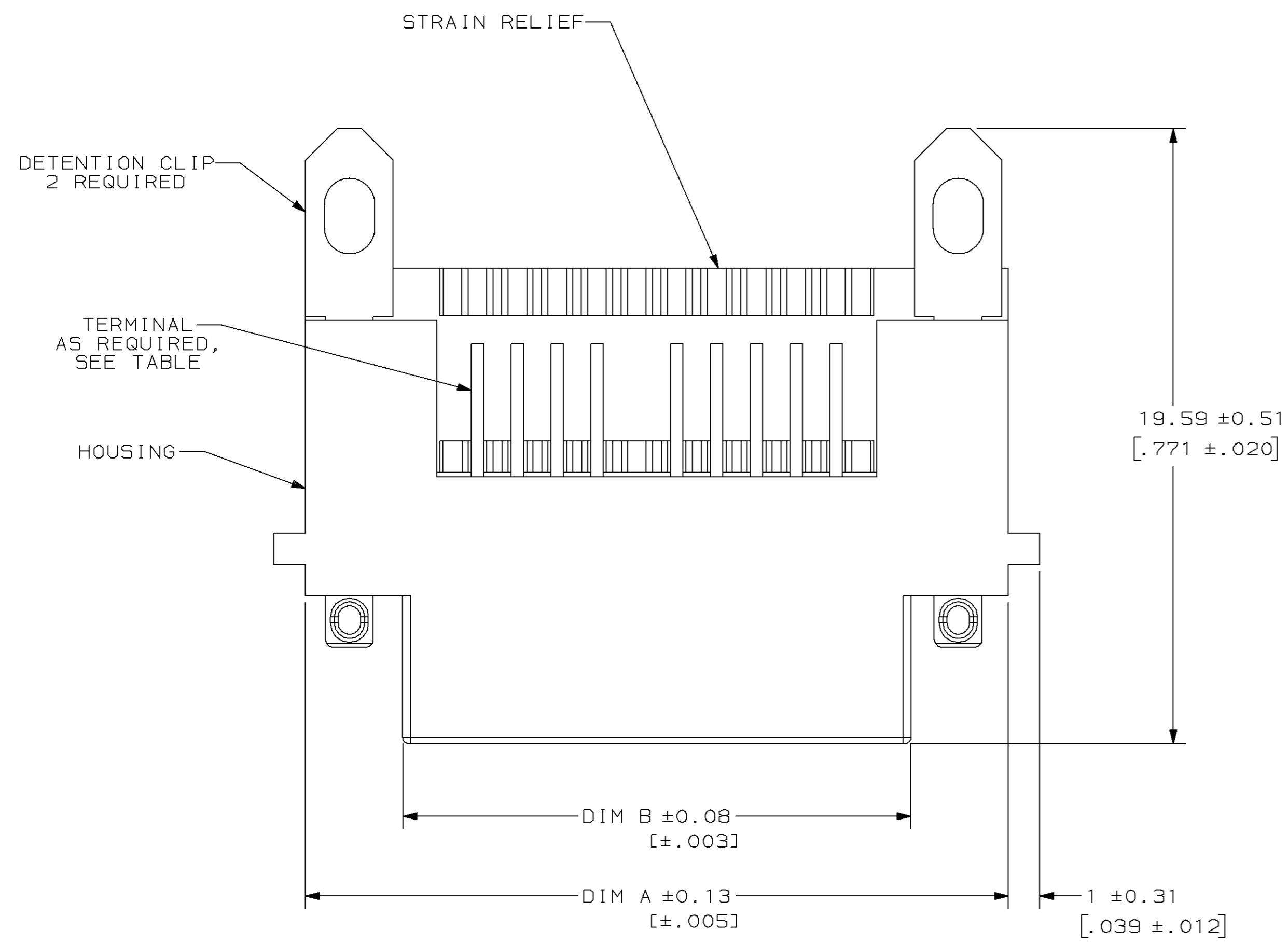
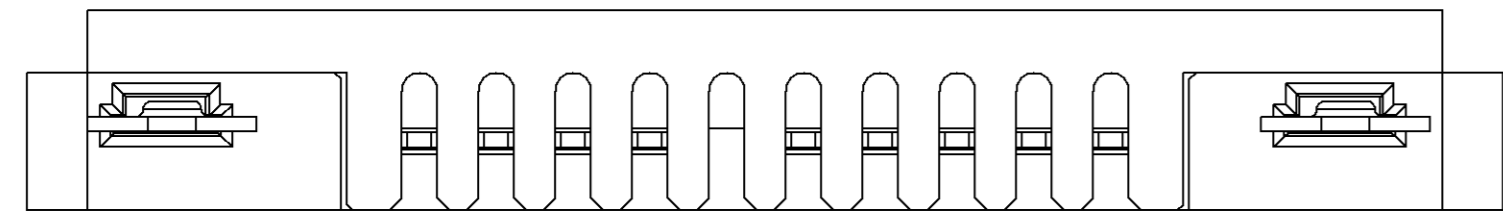

- 1. MATERIAL: HOUSING- LCP POLYESTER MOLDING COMPOUND, BLACK.  
 STRAIN RELIEF - NYLON, FLAME RETARDED MOLDING COMPOUND, BLACK.  
 TERMINALS- 0.254 [.010] THICK PHOSPHOR BRONZE PLATED WITH 1.27 um [.00050] MINIMUM THICK GOLD IN CONTACT AREA AND 3.8 um [.000150] MINIMUM THICK TIN-LEAD ON SOLDER TINES OVER 2.54 um [.000100] MINIMUM THICK NICKEL UNDERPLATE.  
 DETENTION CLIPS- TIN-LEAD OVER NICKEL PLATED BRASS.
- 2. DIMENSIONS ARE MAXIMUM UNLESS OTHERWISE SPECIFIED.
- 3. DESIGNATIONS IN PARENTHESES ( ) ARE FOR REFERENCE ONLY.

SUPERSEDED BY 558314-1

16.26 [.640]	22.4 [.882]	9 KEYED	557715-3
23.8 [.937]	30.02 [1.182]	15 KEYED	557715-2
DIM B		DIM A	
POSITIONS		PART NO	

DO NOT SCALE PRINT. UNLESS SPECIFIED DIMENSIONS IN mm [INCHES] TOLERANCES ON: 2 PLC DEC ± 3 PLC DEC ± ANGLES ±	DR 6-30-92 RK BARKER	AMP Incorporated Harrisburg, PA 17105-3608
	CHK 11-5-92 D. HUSSEY	
	APPD 11-6-92 E. MARSH	
MATERIAL	APPD 11-6-92 E. MARSH	NAME
FINISH	PRODUCT SPEC	PLUG ASSEMBLY, MEMORY CARD
	APPLICATION SPEC	SIZE
	WEIGHT	CAGE CODE
		DRAWING NO
		SCALE
		SHEET

THIS DRAWING IS A CONTROLLED DOCUMENT FOR AMP INCORPORATED. IT IS SUBJECT TO CHANGE AND THE CONTROLLING ENGINEERING ORGANIZATION SHOULD BE CONTACTED FOR THE LATEST REVISION.

LOC		DIST		P		F		ZONE		LTR		REVISIONS		DATE	APPD
AA	23												SEE SHEET 1	-	-

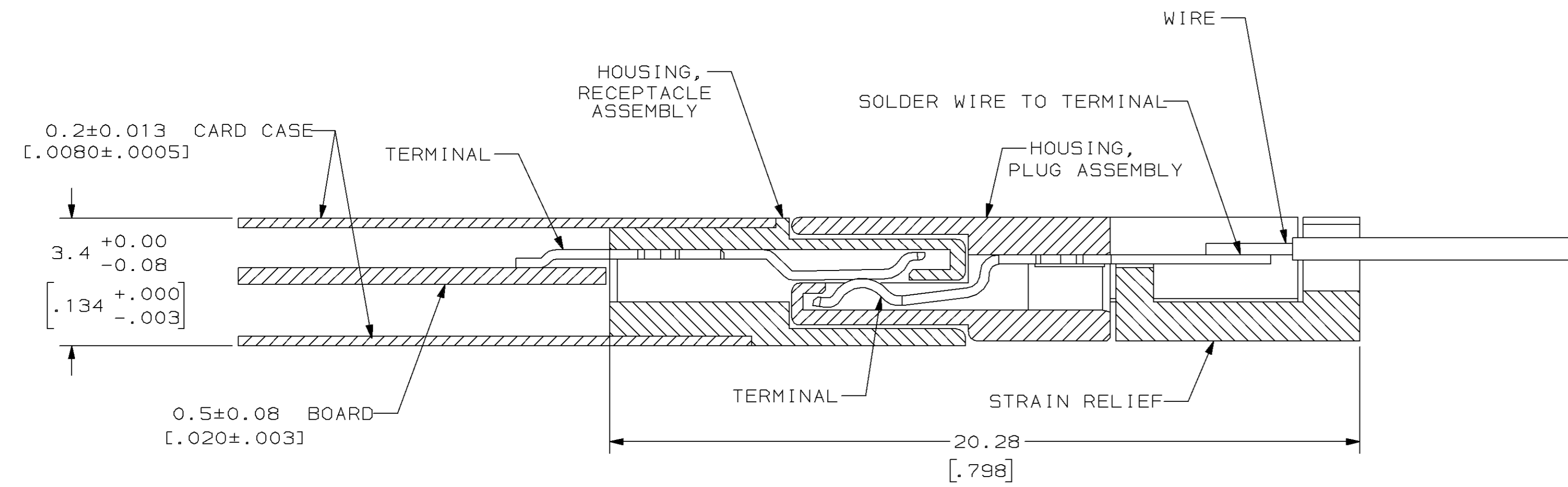

RECEPTACLE ASSEMBLY (TYPE I) MATED TO PLUG ASSEMBLY  
 SCALE 10:1

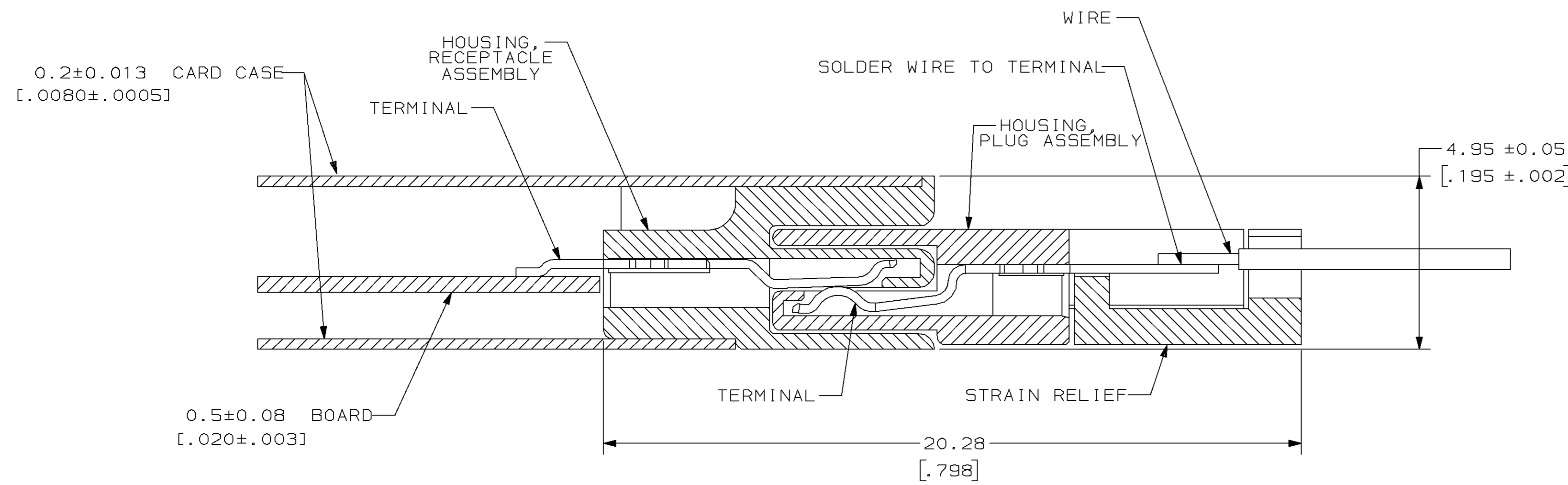

RECEPTACLE ASSEMBLY (TYPE II) MATED TO PLUG ASSEMBLY  
 SCALE 10:1

DO NOT SCALE PRINT. UNLESS SPECIFIED DIMENSIONS IN mm [INCHES]		DR 6-30-92 RK BARKER		PART NO	
TOLERANCES ON:		CHK 11-5-92 D. HUSSEY		AMP Incorporated Harrisburg, PA 17105-3608	
2 PLC DEC ±		APPD 11-6-92 E. MARSH		NAME	
3 PLC DEC ±		APPD 11-6-92 E. MARSH		PLUG ASSEMBLY, MEMORY CARD	
ANGLES ±		PRODUCT SPEC		SIZE	
MATERIAL		APPLICATION SPEC		CAGE CODE	
FINISH		-		DRAWING NO	
-		-		00779	
-		-		C=557715	
-		-		SCALE	
-		-		8:1	
-		-		SHEET	
-		-		20F2	

THIS DRAWING IS A CONTROLLED DOCUMENT FOR AMP INCORPORATED. IT IS SUBJECT TO CHANGE AND THE CONTROLLING ENGINEERING ORGANIZATION SHOULD BE CONTACTED FOR THE LATEST REVISION.